

WARNING

National Cycle windshields and fairings are designed to provide wind protection and increased riding comfort, but not protection in the event of a collision with another vehicle, the road, birds, or any other object.

Our products utilize certain features, patented and otherwise, that may minimize injury in certain accidents, but the possibility of injury exists if the screen is broken or if impacted by an object. Always wear eye protection, helmets and protective clothing. Never ride your motorcycle while under the influence of drugs or alcohol.

All of our products are made in conformance and exceed the requirements of D.O.T. SS205,Z26.1, classifications AS6 and AS7, which covers all safety glazing for motorcycle application.

Never ride your motorcycle with loose windshield mounting hardware. Check the hardware for tightness regularly.

Today's motorcycles are built with enough frame rigidity to withstand the moderate loads imposed on them by the foreseeable addition of a fork mounted windshield.

If the addition of an accessory(ies) adversely affects your motorcycle's stability, immediately remove the accessory(ies). Do not ride a motorcycle that exhibits unsafe handling traits.

Have experienced service personnel correct any problem before riding with the accessory(ies) installed. For further questions concerning handling problems associated with an accessory(ies), contact your dealer, motorcycle manufacturer, or accessory manufacturer.

MAINTENANCE

To clean the screen, wash with a clean soft cloth, plenty of warm water and, if necessary, a non-abrasive soap such as dishwashing liquid. Flannel or soft chamois make good cleaning cloths. Paint, glue residue or grease removal: Moisten cotton with Naphtha or Turpentine followed by a wash as above. Apply a high quality plastic cleaner, such as McGuir's Mirror-Glaze MG-17 or Novus #2, to the screen. This will leave a protective coating in the screen making future cleanings easier. Do not clean polycarbonate in hot sun or high temperatures.

Do not clean the screen with glass cleaners. Do not use rain protective products on the screen. The solvent action of the alcohol in these products will destroy the screen. Do not allow brake fluid, alcohol, or strong solvents to contact the screen. Permanent damage will result! To remove fine scratches, use a very soft clean cloth and a fine grade buffing compound. Jewelers rouge or McGuir's Mirror-Glaze MG-10 are best for this type of buffing. We recommend hand buffing.

STORAGE

Do not use low quality vinyl covers or old shower curtains to store your motorcycle or windshield. These products damage the plastic of windshields and the motorcycle body.

TRIMMING

All National Cycle accessory and replacement windscreens are top quality wind protection devices. Proper care can help these windscreens give many years of motorcycling enjoyment.

Because each rider has their own combination of physical height and /or motorcycle accessories, trimming may become necessary for the best installation. National Cycle Plexifairing GT is made from a high impact acrylic and can be trimmed if a few simple procedures are followed. We are sorry, we cannot be responsible for damage to the product that may occur during trimming.



Use of jig saw or sabre saw is not recommended! If the windshield is to be shortened from the top, remember to choose the new height while seated on the motorcycle (both wheels on the ground), with it normally loaded. In all cases you should be able to see over the top of the screen at least by stretching, in case the screen should become opaque because of rain or dirt.

Too much should not be taken off the top as this will affect how far the air shoots off the top of the screen. The rake angle of the screen, which is adjustable in most applications, will also affect how the air comes off the screen.

Mark the line to be cut with a crayon or china marker; these can be easily washed off. DO NOT USE INK OR MARKER TO MARK SCREEN. A ruler or piece of paper can be used as a guide to duplicate the original shape. Secure the windshield by gripping it with your knees. This leaves both hands free for filing or sanding.

The trimming should be done by sanding or filing with a coarse 60-80 grit file. Since shudders, jolts, and sudden shocks can promote cracking, a smooth continuous motion should be used. A flat belt sander will remove material quickly, but keep the sander moving back and forth for a smooth edge.

If a large amount of trimming is required, a band saw can be used safely. Protect the screen with masking tape before cutting. The blade should have about ten teeth per inch. A hack saw will also work well; be careful not to let it bind in the cut.

Once the desired shape is found, use the coarse file or sandpaper to round the edges. Any scratches that result from handling can be removed. Refer to the Maintenance instructions.

REPLACEMENT HARDWARE

Orders can be placed by bag or complete kit. Please buy from your local dealer. He's there to serve you.

Complete Kit: AF

Bag 51- All Pivot Mount Hardware, Left and Right Sides

Bag 52- Telescope Brackets and QuickSet Knobs, Left and Right Sides

Bag 810- All Lower Hardware, Left and Right Sides

Bag 811- Locking Nut and Ball End Uprights, Left and Right Sides

Email parts inquires to: info@nationalcycle.com



national cycle

plexifairing gt

DEALERS: If installing the PLEXIFAIRING GT™

for a customer please give this manual to them. It contains information needed to properly maintain and use this product. This manual is designed for complete product knowledge; part identification, installation, adjustment, precautions, maintenance, and replacement parts. Please take the time to become familiar with your PLEXIFAIRING GT™ to obtain the best results in use.

Attention



Special notes and cautionary measures which can prevent damage to the accessory or motorcycle.

Note:



Tips for facilitation of operation, control and adjustment, as well as maintenance work.

Tools: Grease pencil or crayon to mark handlebar
Flat Blade Screw Driver



Left and right of motorcycle and product are determined while sitting on the bike.

UPPER AND LOWER HARDWARE ASSEMBLIES

1. Open all bags and group parts together as upper and lower assemblies as shown in the diagrams.

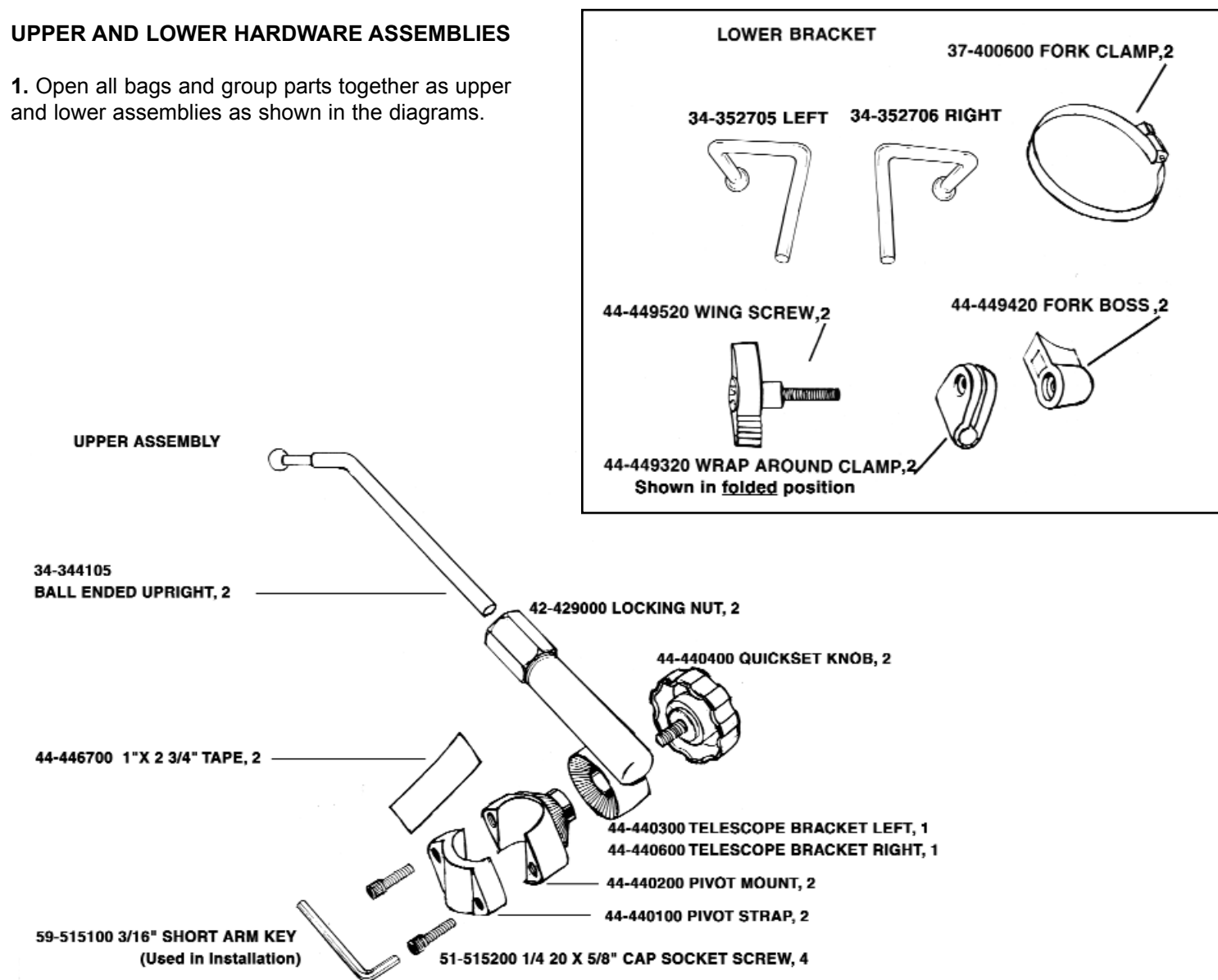

INSTALL UPRIGHTS AND LOWER BRACKETS.

2. Select the left side Lower Rod. Support the fairing and press the left side Lower Rod into the socket. Repeat for right side. **DO NOT USE** lubricants on ball ends or in sockets.
3. Support the fairing on a non-abrasive surface and push in an Upright on each upper socket as shown.

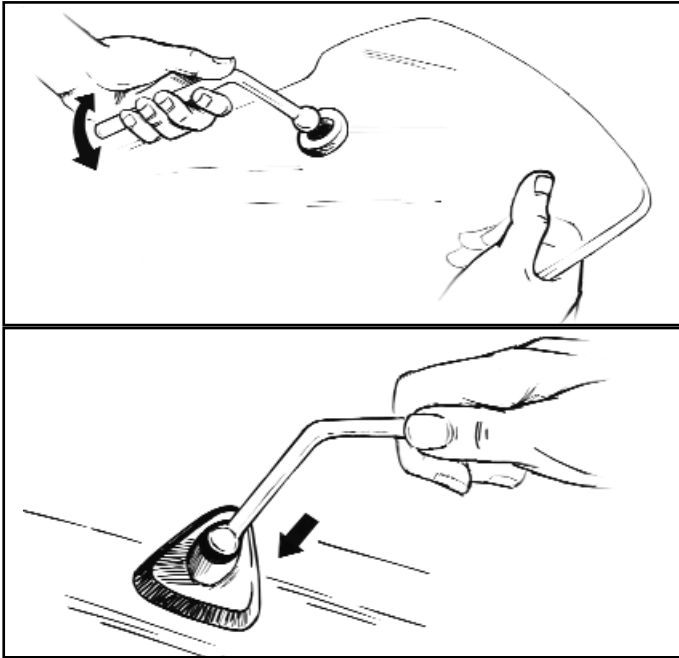

4. Put motorcycle on center or side stand. Straddle front wheel and spring the Plexifairing GT legs apart by pulling back on the handlebar portions. Now slide fairing on the bike. Be careful not to snag any control cables or loose wires. Legs should be behind turn signals.

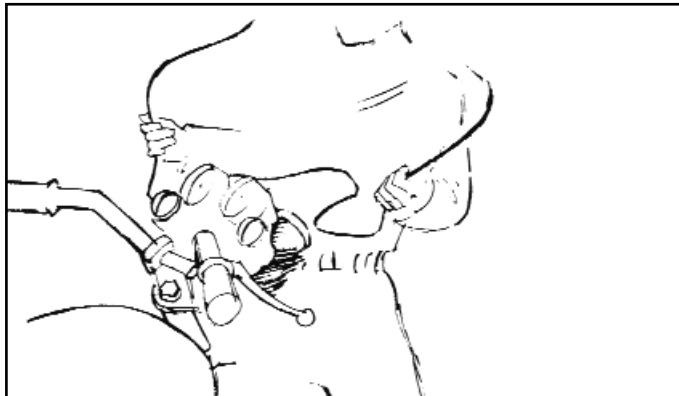

5. Select the left side Telescope Bracket and slide the Bracket onto the Upright. Repeat for right side.

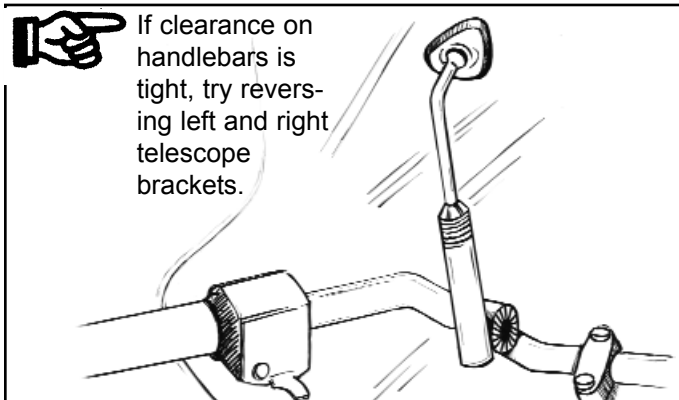

NOTE: The headlight rubber can sit on the headlight of the motorcycle or 1-2" above headlight if you prefer.

6. Determine where to mount Pivot Mounts by positioning the Telescope Brackets to handlebars. Try to achieve as closely as possible:

- A.** Minimize Upright extension from Telescope Bracket. Slide handlebar Pivot assembly up the bar to reduce this.
- B.** Have the Upright / Telescope Bracket combination at about a 45 degree angle or even more horizontal with respect to the road. More vertical angles are slightly less rigid.

7. Once position has been determined mark bar with grease pencil or masking tape. Remove fairing from motorcycle for safekeeping or let rest back against instrument cluster and handlebars.

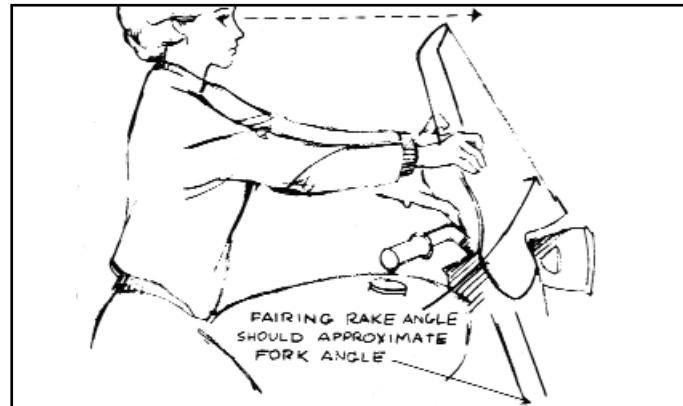

INSTALL PIVOT MOUNTS.

8. Place 1 piece of Double Stick Tape around handlebars in location of pivot mount. The tape is necessary to avoid rotational slippage on some bikes. Install the Pivot Mounts to your handlebars by attaching the Pivot Mount to Pivot Strap with the 1/4 20 bolts until snug, **BUT NOT TIGHT**. Use wrench supplied in hardware kit. Be sure both sides are symmetrical.

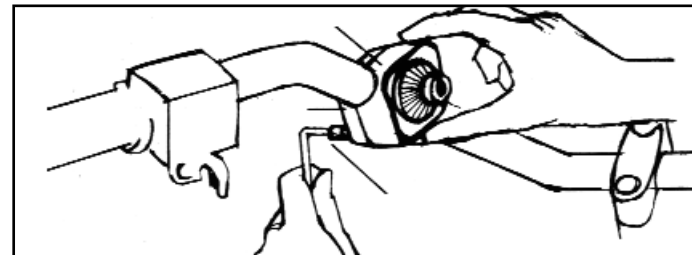

9. Remove Telescope Brackets now and **loosely** screw on Locking Nuts and replace Telescope Brackets on Uprights.

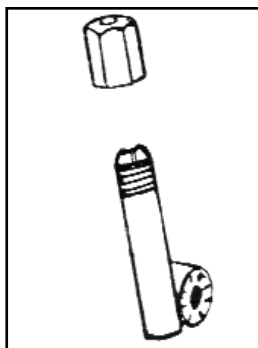

10. Reposition Plexifairing GT on motorcycle. Engage Telescope Bracket with Pivot Mount and secure with QuickSet Knob. **HAND TIGHTEN LOCKING NUTS UNTIL FINAL ADJUSTMENT IS COMPLETE.**

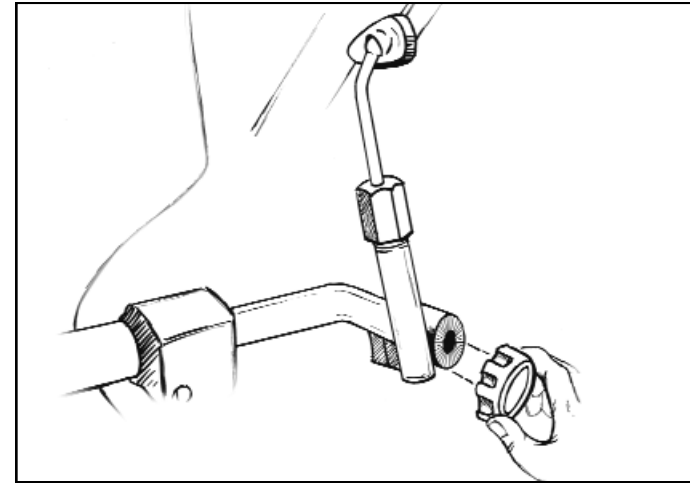

LOWER HARDWARE

11. Examine lower bracket area and select best location for Fork Boss.

- A & C** Sometimes interfere with tank at full fork lock.
- B.** Is good but usually is prohibited by headlight shell interference. C&D are usually where you will find the best clearance.



The lower bracket can be rotated in any direction (up, down, to the front of fork) necessary for proper clearance. Where the lower leg area of the fairing falls in relation to the fork tube will also vary. Some installations will require fairing leg to be even with, or possibly in front of the fork leg.

Photo shows two possible fork boss positions. Left side positions the fork boss to the front of the fork, right side to the rear. Note the position of the worm screw, cosmetically it looks best when positioned to inside of fork.

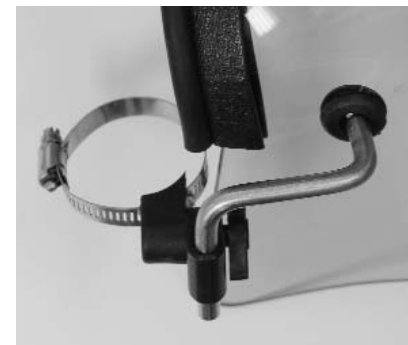
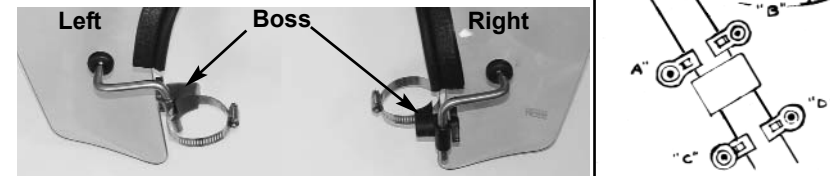

12. Thread Fork Clamp thru Fork Boss and tighten loosely around fork. Cosmetically it is preferable to have the screw of the Fork Clamp facing toward rider on inside of fork leg. Cut off excess strap with diagonal cutters after final adjustment.

INSTALL WRAP-AROUND CLAMP

Flex wrap-around clamp a few times to remove stiffness.

13. Place wrap-around clamp on knurled area of lower bracket where it best aligns with Fork Boss. Push Wing Screw through and then insert and tighten into Fork Boss. **TIGHTEN STAINLESS FORK CLAMPS AFTER WING SCREW IS TIGHT.**

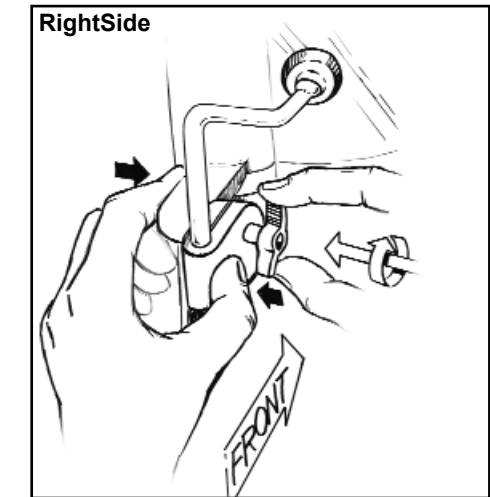

FINAL ADJUSTMENT

14. Sit on seat in normal riding position with motorcycle off center stand. Grip top of Plexifairing GT and position screen to achieve the following:

A. No interference with cables, full turn left and right clearance for fork lock and gas tank, turn signal, rearview mirror and /or radiator.

B. Rake angle should approximate fork angle. **TIGHTEN FULLY:** Locking Nuts (wrap paper or cloth around nuts to avoid scuffs), Quickset Knob and Fork Clamps. Also be sure Hex Bolts of Pivot Mounts are fully tightened. Refer to page four of this manual for additional information.

